



AMDV040N048VRH

Automotive MOSFET 40V 4.8mΩ 80A

FEATURES

- Trench power MOSFET technology
- Single N-channel trench, Normal level
- Enhanced avalanche ruggedness
- 100% Avalanche tested
- Maximum 175°C junction temperature
- AEC-Q101 qualified and PPAP capable

APPLICATIONS

- Switching applications
- Motor drive systems

KEY PERFORMANCE PARAMETERS

| | | |
|--------------------------------|--------|-------------|
| V_{DS} | 40 | V |
| $R_{DS(on), typ.}$ | 0.0035 | Ω |
| I_D | 80 | A |
| Q_G | 21 | nC |
| Junction temperature, $_{max}$ | 175 | $^{\circ}C$ |

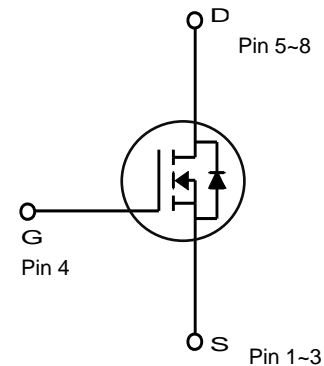
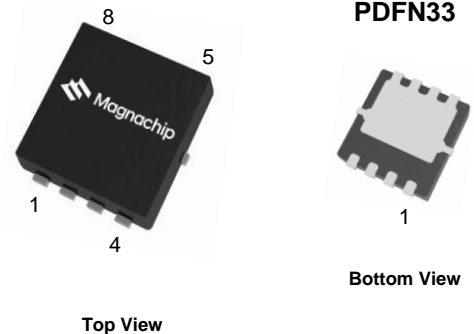

ORDERING INFORMATION

| Type / Ordering Code | Package | Marking | Packing | RoHS Status |
|----------------------|---------|---------|-------------|--------------|
| AMDV040N048VRH | PDFN33 | 040N048 | Tape & Reel | Halogen Free |

<http://www.magnachip.com/>

ABSOLUTE MAXIMUM RATINGS, at $T_c = 25^\circ\text{C}$, unless otherwise specified

| PARAMETER | | SYMBOL | RATING | UNIT |
|--|-------------------------|----------------|------------|------------------|
| Drain-source Voltage | | V_{DS} | 40 | V |
| Gate-source Voltage | | V_{GS} | ± 20 | |
| Drain current | $T_c=25^\circ\text{C}$ | I_D | 80 | A |
| | $T_c=100^\circ\text{C}$ | | 57 | |
| ¹⁾ Pulsed drain current | $T_c=25^\circ\text{C}$ | I_{DM} | 320 | |
| Total power dissipation | $T_c=25^\circ\text{C}$ | P_{tot} | 58 | W |
| | $T_c=100^\circ\text{C}$ | | 29 | |
| ²⁾ Avalanche energy, single pulse | | E_{AS} | 61 | mJ |
| Operating and storage temperature | | T_j, T_{stg} | - 55 ~ 175 | $^\circ\text{C}$ |

THERMAL CHARACTERISTICS

| PARAMETER | | SYMBOL | RATING | UNIT |
|--|--|-----------------|--------|------|
| Thermal resistance, junction - case | | $R_{\theta JC}$ | 2.6 | K/W |
| ³⁾ Thermal resistance, junction - ambient | | $R_{\theta JA}$ | 60 | |

ELECTRICAL CHARACTERISTICS (T_J = 25°C)

STATIC CHARACTERISTICS

| PARAMETER | Symbol | Min. | Typ. | Max. | Unit | Conditions / Note |
|----------------------------------|----------------------|------|------|-------|------|---|
| Drain-source breakdown voltage | V _{(BR)DSS} | 40 | - | - | V | V _{GS} =0 V, I _D =250 μA |
| Gate threshold voltage | V _{GS(th)} | 2.25 | - | 3.75 | V | V _{DS} =V _{GS} , I _D =250 μA |
| Zero gate voltage drain current | I _{DSS} | - | - | 1 | μA | V _{DS} =40 V, V _{GS} =0 V |
| Gate-source leakage current | I _{GSS} | - | - | ± 100 | nA | V _{GS} =±20 V, V _{DS} =0 V |
| Drain-source on-state resistance | R _{DS(on)} | - | 4.4 | 6.6 | mΩ | V _{GS} =7 V, I _D =20 A |
| | | - | 3.5 | 4.8 | | V _{GS} =10 V, I _D =20 A |
| ⁴⁾ Gate resistance | R _G | - | 2.8 | - | Ω | f=1 MHz |
| ⁴⁾ Transconductance | g _{fs} | - | 65 | - | S | V _{DS} =10 V, I _D =40 A |

⁴⁾ DYNAMIC CHARACTERISTICS

| PARAMETER | Symbol | Min. | Typ. | Max. | Unit | Conditions / Note |
|------------------------------|---------------------|------|------|------|------|---|
| Input capacitance | C _{iss} | - | 1460 | - | pF | V _{GS} =0 V, V _{DS} =20 V, f=1 MHz |
| Output capacitance | C _{oss} | - | 270 | - | | |
| Reverse transfer capacitance | C _{rss} | - | 26 | - | | |
| Turn-on delay time | t _{d(on)} | - | 15 | - | ns | V _{DD} =20 V, V _{GS} =10 V, I _D =40 A, R _{G,ext} =3 Ω |
| Rise time | t _r | - | 7 | - | | |
| Turn-off delay time | t _{d(off)} | - | 27 | - | | |
| Fall time | t _f | - | 9 | - | | |

⁴⁾ GATE CHARGE CHARACTERISTICS

| PARAMETER | Symbol | Min. | Typ. | Max. | Unit | Conditions / Note |
|--------------------------|----------------------|------|------|------|------|---|
| Gate to source charge | Q _{gs} | - | 7 | - | nC | V _{DD} =32 V, I _D =40 A, V _{GS} =0 to 10 V |
| Gate charge at threshold | Q _{gs(th)} | - | 4 | - | | |
| Gate to drain charge | Q _{gd} | - | 5 | - | | |
| Switching charge | Q _{sw} | - | 7 | - | | |
| Gate charge total | Q _g | - | 21 | - | | |
| Gate plateau voltage | V _{plateau} | - | 5.1 | - | V | |

SOURCE-DRAIN DIODE

| PARAMETER | Symbol | Min. | Typ. | Max. | Unit | Conditions / Note |
|--|----------------------|------|------|------|------|--|
| ⁴⁾ Diode continuous forward current | I _S | - | - | 80 | A | - |
| ⁴⁾ Diode pulse current | I _{S,pulse} | - | - | 320 | | pulsed; t _p ≤ 10 μs |
| Diode forward voltage | V _{SD} | - | 0.9 | 1.1 | V | V _{GS} =0 V, I _F =20 A |
| ⁴⁾ Reverse recovery time | t _{rr} | - | 48 | - | ns | I _F =40 A, d _{iF} /dt=100 A/μs |
| ⁴⁾ Reverse recovery charge | Q _{rr} | - | 52 | - | nC | |

Notes

- Pulse width limited by T_{Jmax}
- Starting T_J=25°C, L=1mH, I_{AS}=11A, V_{DD}=36V, V_{GS}=10V
- Surface mounted FR-4 board by JEDEC (jesd51-7)
- The parameter is not subject to production testing - guaranteed by design.

ELECTRICAL CHARACTERISTICS DIAGRAMS (25 °C, unless otherwise noted)

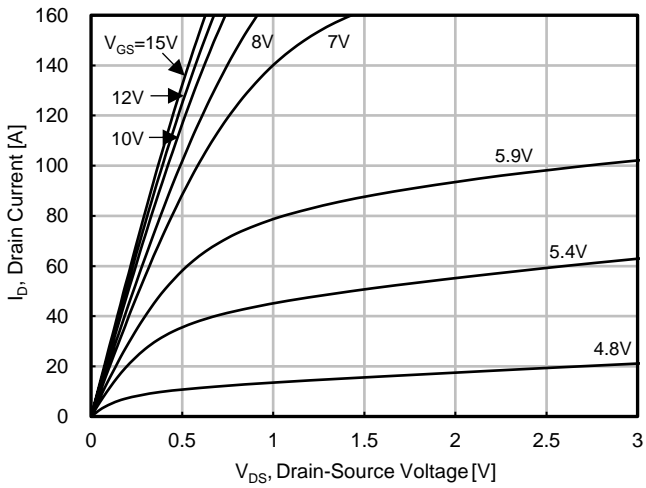

Fig. 1. Typ. Output Characteristics

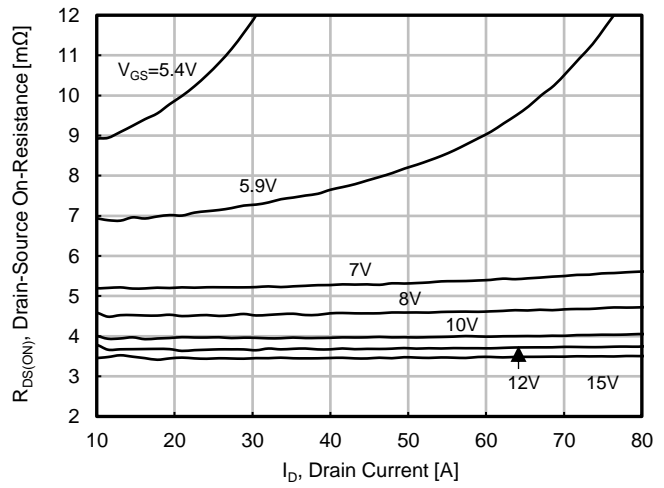

Fig. 2. Typ. Drain to Source On-Resistance

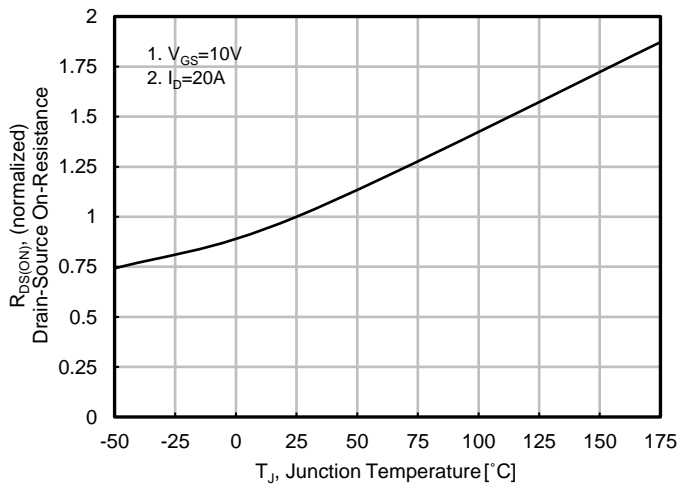

Fig. 3. On-Resistance vs. Junction Temperature

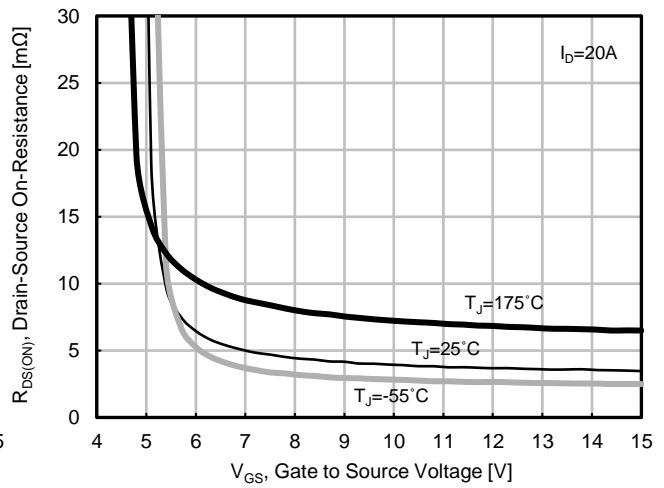

Fig. 4. On-Resistance vs. Gate to Source Voltage

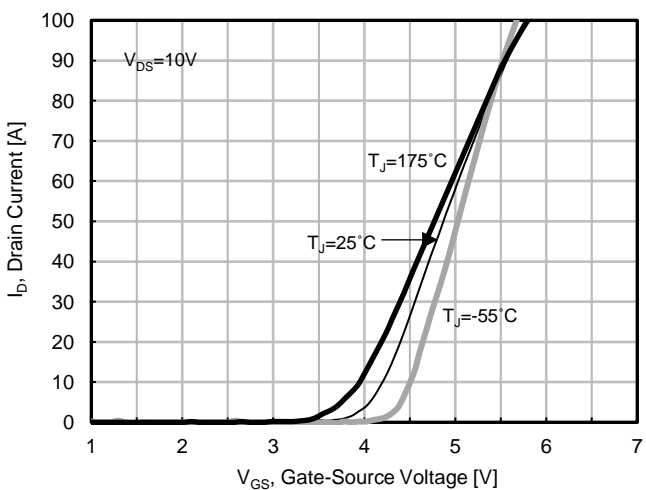

Fig. 5. Typ. Transfer Characteristics

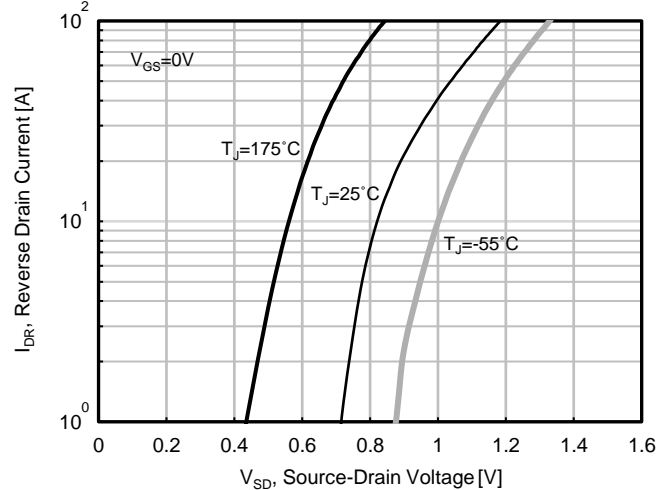

Fig. 6. Forward Characteristics of Reverse Diode

ELECTRICAL CHARACTERISTICS DIAGRAMS (25 °C, unless otherwise noted)

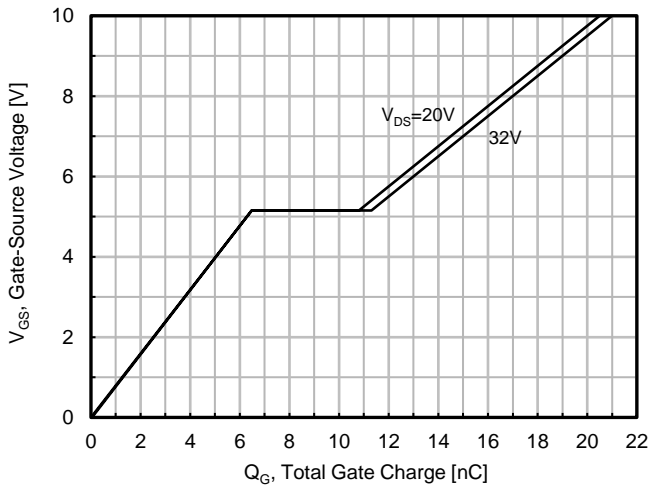

Fig. 7. Typ. Gate Charge

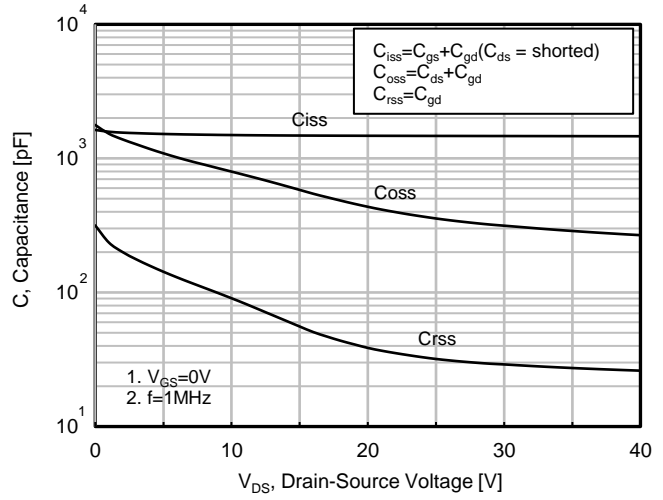

Fig. 8. Typ. Capacitances

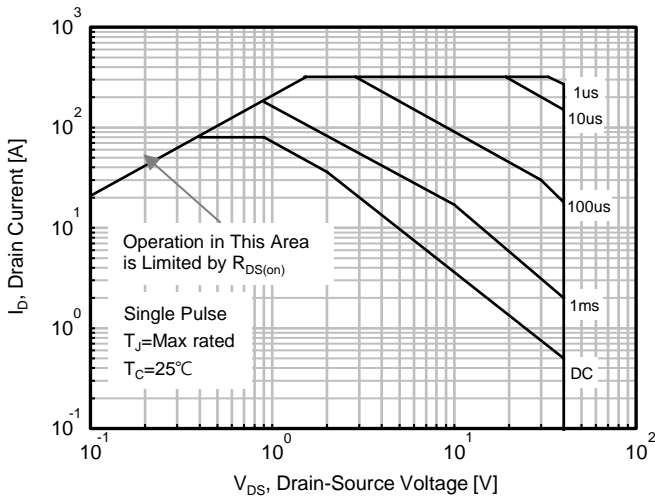

Fig. 9. Safe Operating Area

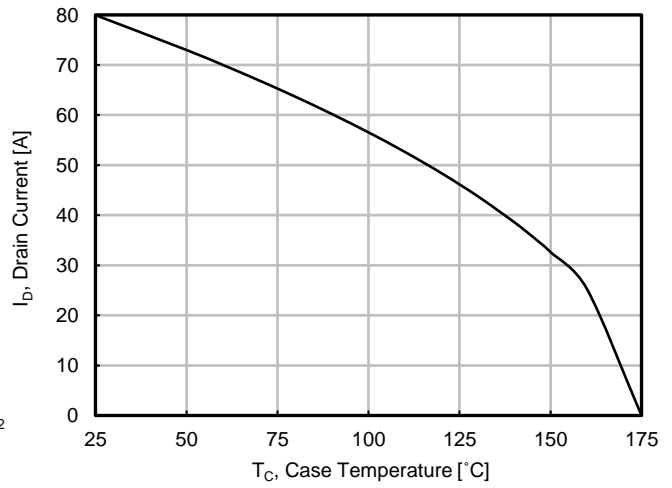

Fig. 10. Drain Current vs. Temperature

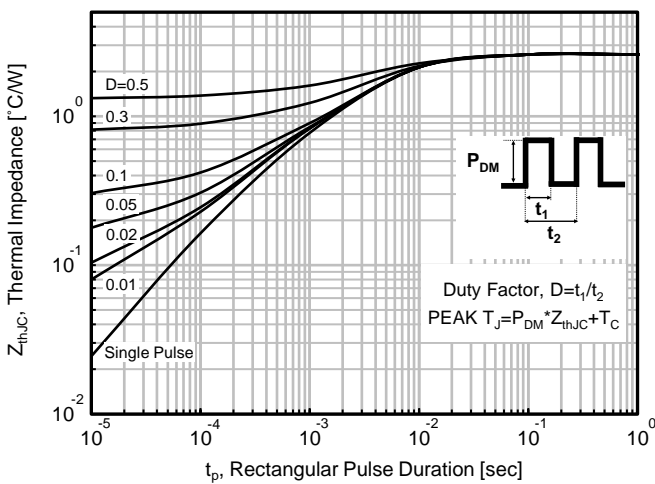

Fig. 11. Transient Thermal Impedance

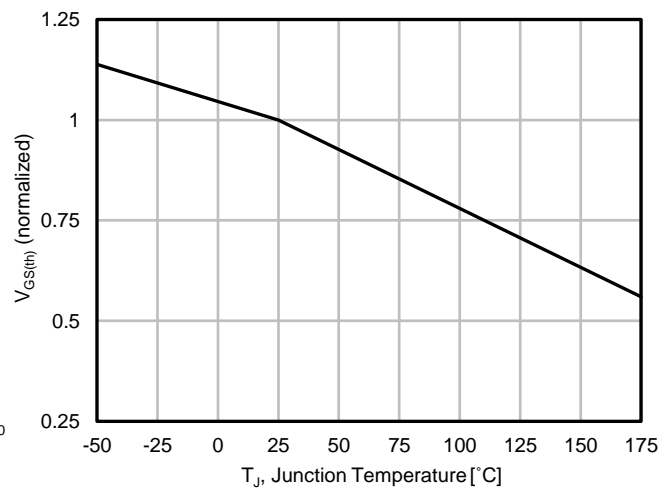

Fig. 12. V_GS(th) Variation with Temperature (Normalized)

ELECTRICAL CHARACTERISTICS DIAGRAMS (25 °C, unless otherwise noted)

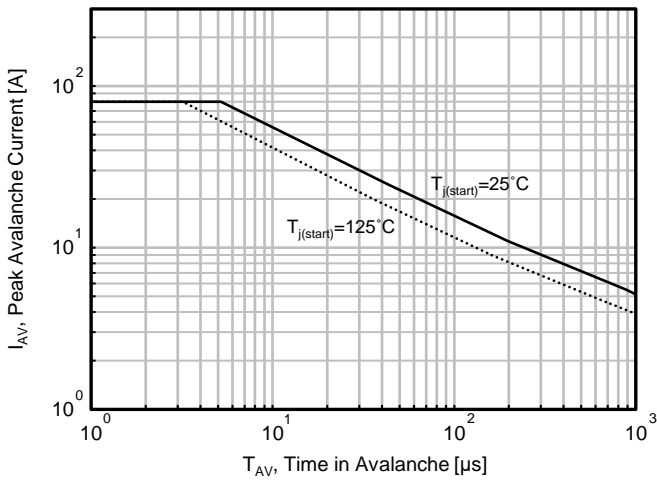
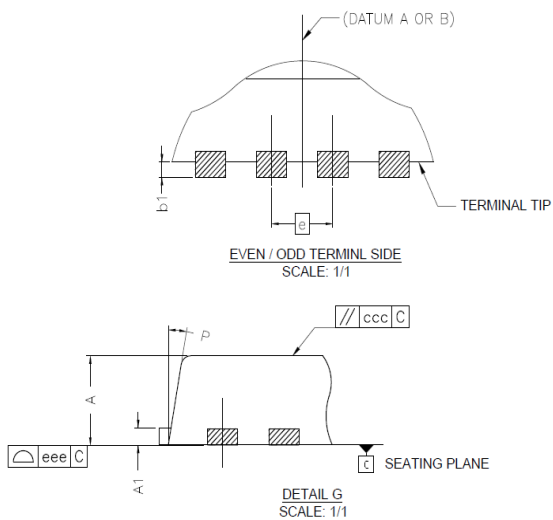
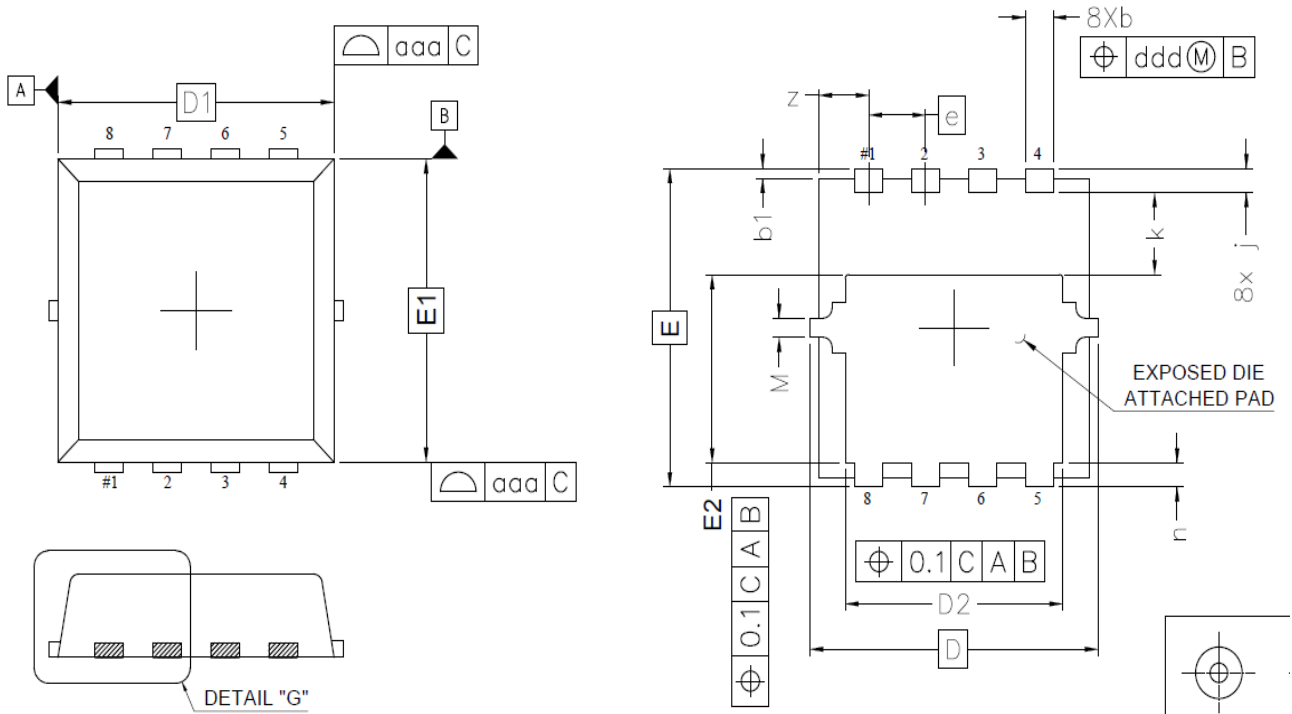

Fig. 13. Avalanche Characteristics

Package Outlines

PDFN33



| SYMBOL | MIN | MAX | SYMBOL | MIN | MAX |
|--------|----------|------|--------|------|-----|
| A | 0.80 | 0.90 | M | 0.20 | |
| A1 | 0.12 | 0.22 | P | 9° | 11° |
| b | 0.22 | 0.42 | z | 0.58 | |
| b1 | 0.05 | 0.15 | aaa | 0.10 | |
| D | 3.30 BSC | | ccc | 0.10 | |
| D1 | 3.10 BSC | | ddd | 0.05 | |
| D2 | 2.29 | 2.69 | eee | 0.05 | |
| E | 3.30 BSC | | | | |
| E1 | 3.10 BSC | | | | |
| E2 | 1.85 | 2.05 | | | |
| e | 0.65 BSC | | | | |
| j | 0.15 | 0.35 | | | |
| k | 0.75 | 0.95 | | | |
| n | 0.15 | 0.35 | | | |

Notes

Package body size, length and width do not include mold flash, protrusions and gate burrs.

DISCLAIMER :

The Products are not designed for use in hostile environments, including, without limitation, aircraft, nuclear power generation, medical appliances, and devices or systems in which malfunction of any Product can reasonably be expected to result in a personal injury. Seller's customers using or selling Seller's products for use in such applications do so at their own risk and agree to fully defend and indemnify Seller.

Magnachip reserves the right to change the specifications and circuitry without notice at any time. Magnachip does not consider responsibility for use of any circuitry other than circuitry entirely included in a Magnachip product.  Magnachip is registered trademark of Magnachip Semiconductor Ltd.