

# MMP60R260S6Z

## 600V 0.26Ω N-channel MOSFET

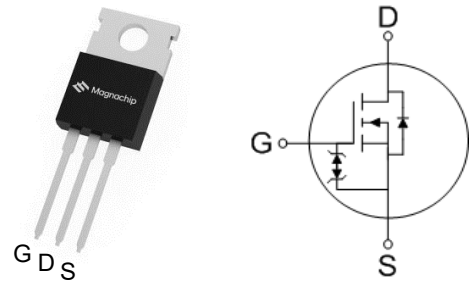
### ■ Description

Superior 6<sup>th</sup> generation SJ MOSFETs (S6-series) are cutting-edge high voltage power MOSFETs, based on Magnachip's extensive design expertise and years of experience. The main strengths of S6-series are low on-resistance, low gate charge and reduced tendency for ringing. As a result, its switching loss is very low, making it optimized for switching applications. Moreover, these user friendly devices offer the advantages of improved ruggedness and remarkable ESD capability by integrated Zener diode, making it an ideal choice for designers.

### ■ Key Parameters

Parameter	Value	Unit
$V_{DS} @ T_{j,max}$	650	V
$R_{DS(on),max}$	0.26	Ω
$V_{TH,typ}$	3.5	V
$I_D$	12	A
$Q_{g,typ}$	22.9	nC

### ■ Package & Internal circuit



### ■ Features

- Low power loss by high speed switching and low on-resistance
- 100% avalanche tested
- Green package – Pb free plating, halogen free
- Zener-integrated

### ■ Applications

- PFC power supply stages
- Switching applications
- Adapters
- DC-DC converters

### ■ Ordering Information

Order Code	Marking	Temp. Range	Package	Packing	RoHS Status
MMP60R260S6ZRH	60R260S6Z	-55 ~ 150°C	TO-220	Tube	Compliant

**■ Absolute Maximum Rating ( $T_c=25^\circ\text{C}$  unless otherwise specified)**

Parameter	Symbol	Rating	Unit	Note
Drain-source voltage	$V_{DSS}$	600	V	
Gate-source voltage	$V_{GSS}$	$\pm 25$	V	
Continuous drain current <sup>1)</sup>	$I_D$	12	A	$T_c=25^\circ\text{C}$
		7.6	A	$T_c=100^\circ\text{C}$
Pulsed drain current <sup>2)</sup>	$I_{DM}$	36	A	
Power dissipation	$P_D$	53	W	
Single-pulse avalanche energy <sup>3)</sup>	$E_{AS}$	38	mJ	
MOSFET $dv/dt$ ruggedness	$dv/dt$	80	V/ns	
Continuous diode forward current	$I_{SD}$	12	A	
Diode $dv/dt$ ruggedness <sup>4)</sup>	$dv/dt$	50	V/ns	
Storage temperature	$T_{stg}$	-55 ~ 150	$^\circ\text{C}$	
Maximum operating junction temperature	$T_j$	150	$^\circ\text{C}$	

1)  $I_D$  limited by maximum junction temperature, Duty cycle  $D=0.5$

2) Pulse width  $t_P$  limited by  $T_{j,max}$

3)  $I_{AS} : 1.0 \text{ A}$

4)  $I_{SD} \leq I_D$ ,  $V_{DS,peak} \leq 400\text{V}$ ,  $di/dt \leq 900\text{A}/\mu\text{s}$

**■ Thermal Characteristics**

Parameter	Symbol	Value	Unit
Thermal resistance, junction-case max	$R_{thJC}$	2.35	$^\circ\text{C}/\text{W}$
Thermal resistance, junction-ambient max	$R_{thJA}$	62.5	$^\circ\text{C}/\text{W}$

**■ Static Characteristics ( $T_c=25^\circ\text{C}$  unless otherwise specified)**

Parameter	Symbol	Min.	Typ.	Max.	Unit	Test Condition
Drain-source breakdown voltage	$V_{(BR)DSS}$	600	-	-	V	$V_{GS} = 0V, I_D = 1mA$
Gate threshold voltage	$V_{GS(th)}$	2.5	3.5	4.5	V	$V_{DS} = V_{GS}, I_D = 250\mu A$
Zero gate voltage drain current	$I_{DSS}$	-	-	1	$\mu A$	$V_{DS} = 600V, V_{GS} = 0V$
Gate leakage current	$I_{GSS}$	-	-	10	$\mu A$	$V_{GS} = \pm 25V, V_{DS} = 0V$
Drain-source on-state resistance	$R_{DS(ON)}$	-	0.231	0.260	$\Omega$	$V_{GS} = 10V, I_D = 3.8A$

**■ Dynamic Characteristics ( $T_c=25^\circ\text{C}$  unless otherwise specified)**

Parameter	Symbol	Min.	Typ.	Max.	Unit	Test Condition
Input capacitance	$C_{iss}$	-	911	-	pF	$V_{DS} = 400V, V_{GS} = 0V,$ $f = 250kHz$
Output capacitance	$C_{oss}$	-	20.5	-		
Reverse transfer capacitance	$C_{rss}$	-	4.0	-		
Effective output capacitance energy related <sup>5)</sup>	$C_{o(er)}$	-	30.9	-		
Effective output capacitance time related <sup>6)</sup>	$C_{o(tr)}$	-	187	-		$V_{DS} = 0V \text{ to } 400V,$ $V_{GS} = 0V, f = 250kHz$
Turn-on delay time	$t_{d(on)}$	-	20	-	ns	$V_{GS} = 10V, R_G = 25\Omega,$ $V_{DD} = 300V, I_D = 12A$
Rise time	$t_r$	-	39	-		
Turn-off delay time	$t_{d(off)}$	-	74	-		
Fall time	$t_f$	-	21	-		
Total gate charge	$Q_g$	-	22.9	-	nC	$V_{GS} = 10V, V_{DD} = 400V,$ $I_D = 3.8A$
Gate-source charge	$Q_{gs}$	-	4.6	-		
Gate-drain charge	$Q_{gd}$	-	10.0	-		
Gate resistance	$R_G$	-	9.5	-	$\Omega$	$V_{GS} = 0V, f = 1MHz$

5)  $C_{o(er)}$  is a capacitance that gives the same stored energy as  $C_{oss}$  while  $V_{DS}$  is rising from 0 to 400V

6)  $C_{o(tr)}$  is a capacitance that gives the same charging time as  $C_{oss}$  while  $V_{DS}$  is rising from 0 to 400V

**■ Reverse Diode Characteristics ( $T_c=25^\circ\text{C}$  unless otherwise specified)**

Parameter	Symbol	Min.	Typ.	Max.	Unit	Test Condition
Diode forward voltage	$V_{SD}$	-	-	1.4	V	$I_{SD} = 3.8\text{A}$ , $V_{GS} = 0\text{V}$
Reverse recovery time	$t_{rr}$	-	207	-	ns	$I_{SD} = 3.8\text{A}$ $di/dt = 100\text{A}/\mu\text{s}$ $V_{DD} = 400\text{V}$
Reverse recovery charge	$Q_{rr}$	-	1.6	-	$\mu\text{C}$	
Reverse recovery current	$I_{rrm}$	-	15.7	-	A	

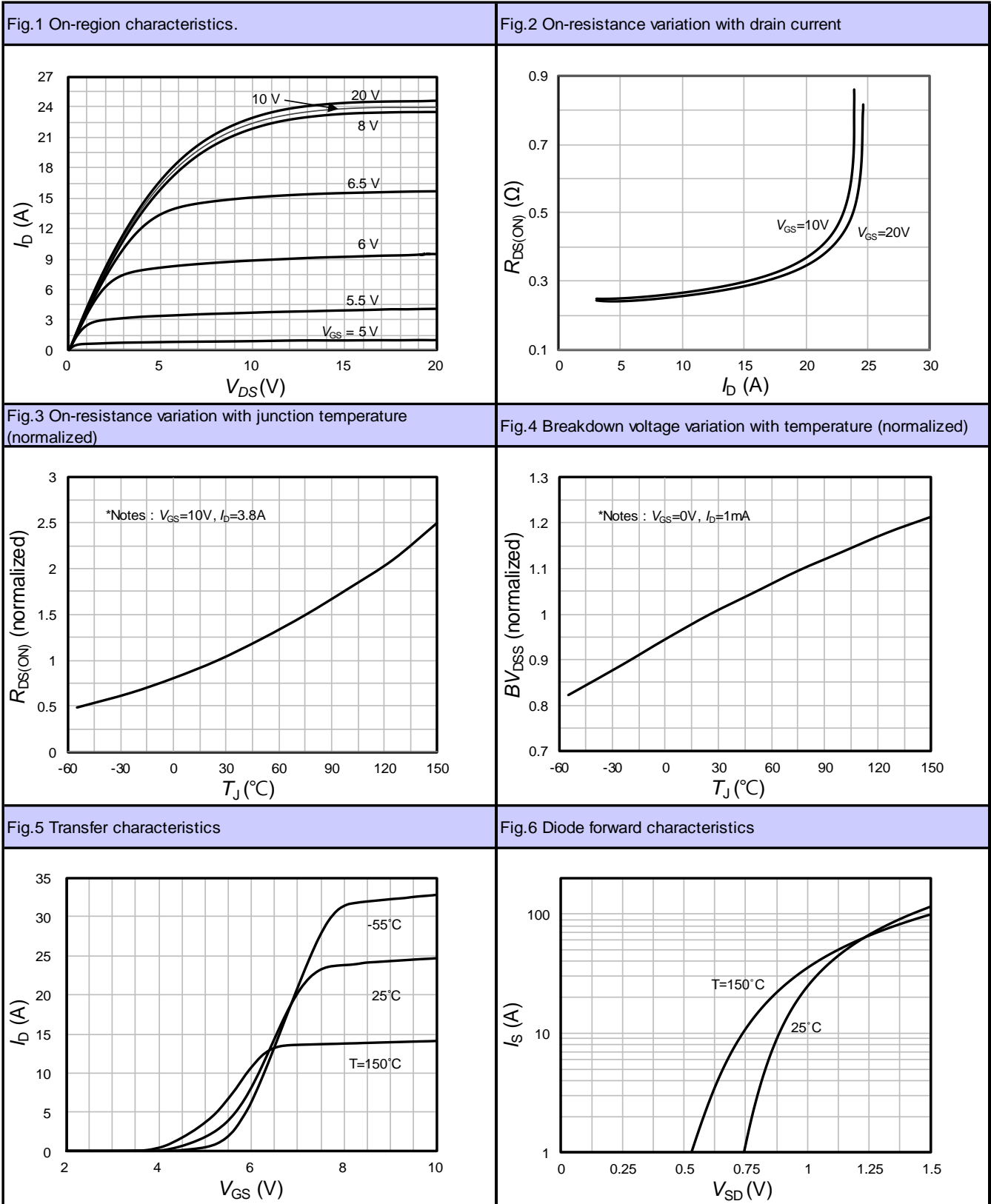
**■ Characteristic graph**


Fig.7 Gate charge characteristics

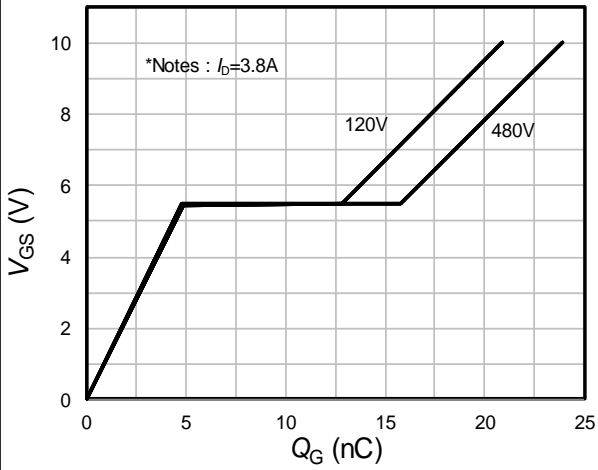


Fig.8 Capacitance characteristics

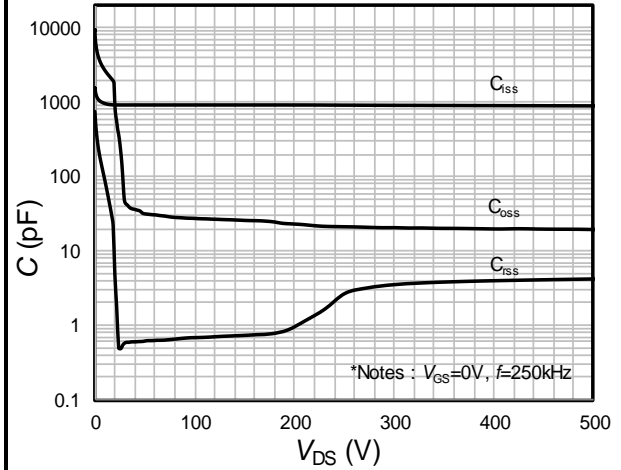


Fig.9 Threshold voltage variation with junction temperature

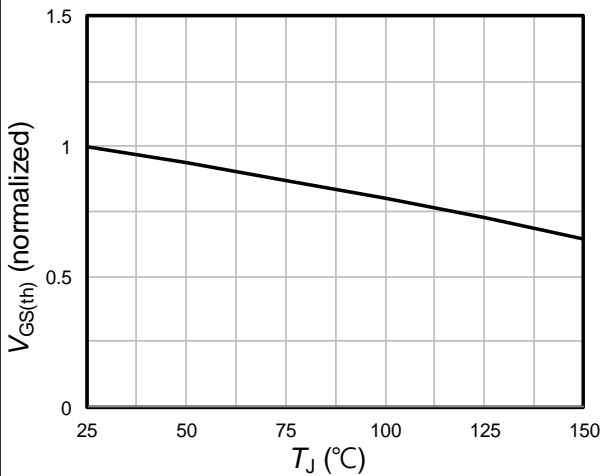


Fig.10 Drain current

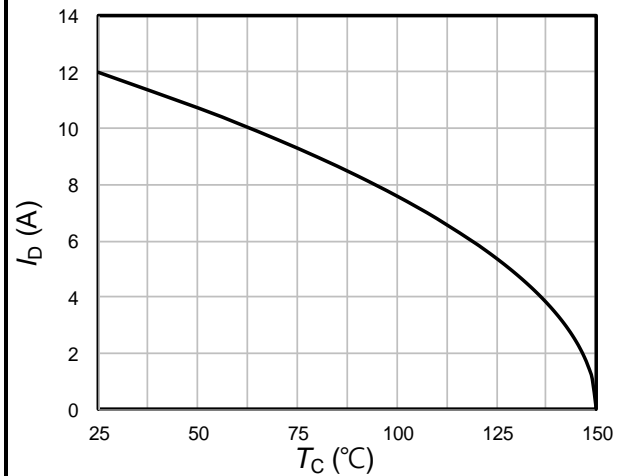


Fig.11 Power dissipation variation with pulse time

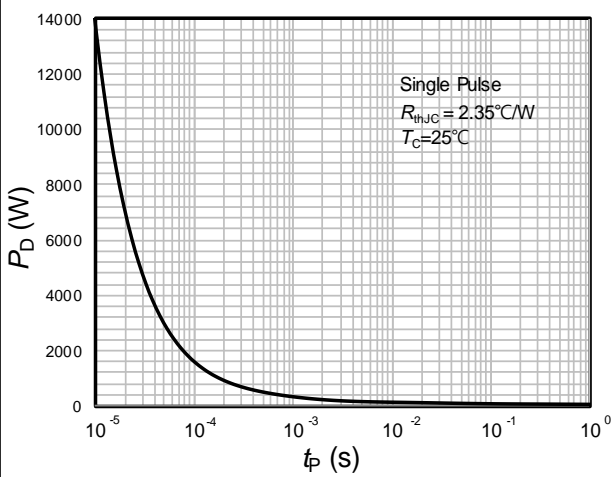
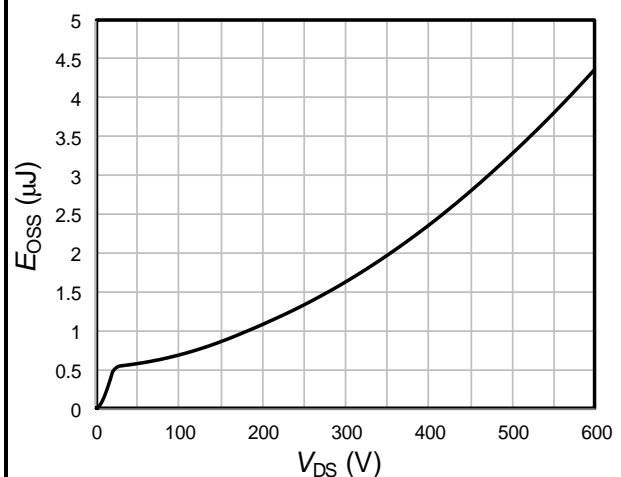
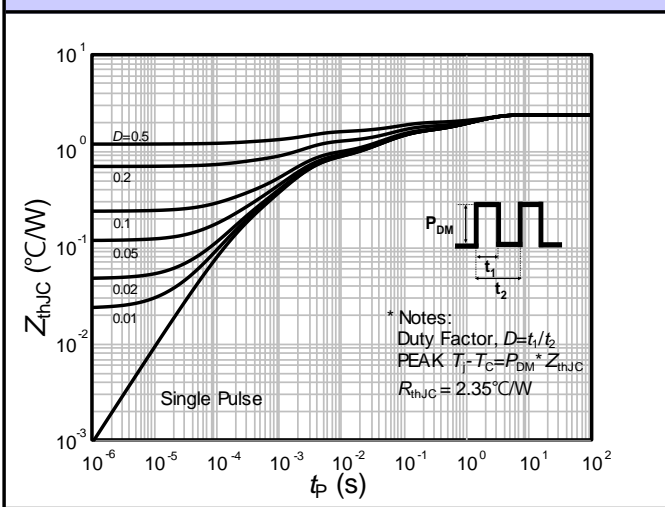
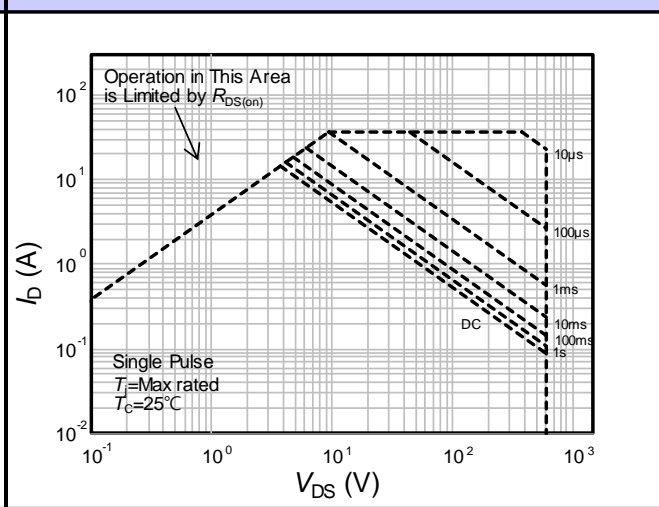


Fig.12 Output capacitance stored energy



**Fig.13 Transient thermal response**

**Fig.14 Safe operating area**


■ Test Circuit

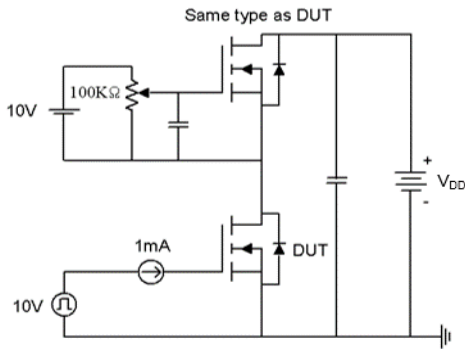


Fig15-1. Gate charge measurement circuit

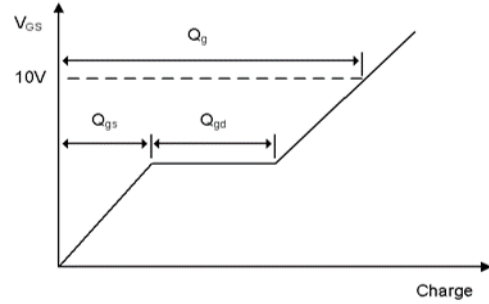


Fig15-2. Gate charge waveform

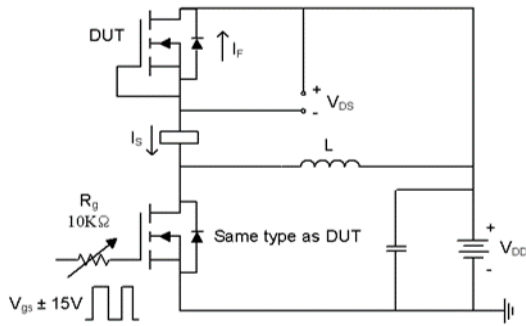


Fig16-1. Diode reverse recovery test circuit

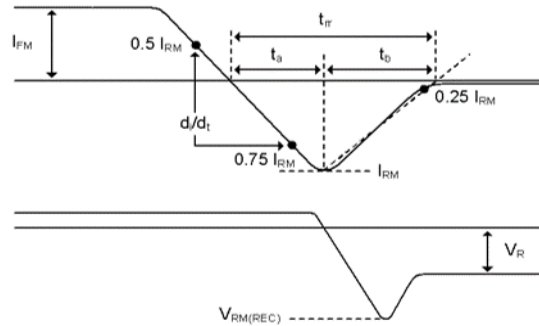


Fig16-2. Diode reverse recovery test waveform

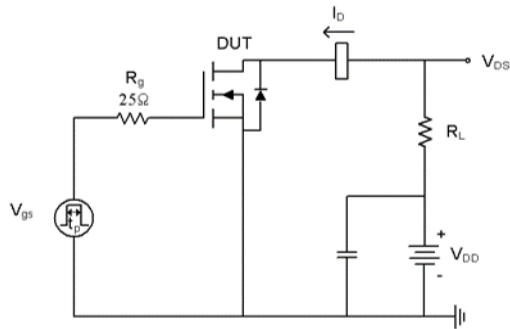


Fig17-1. Switching time test circuit for resistive load

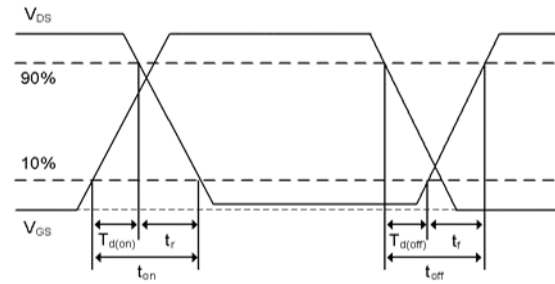


Fig17-2. Switching time waveform

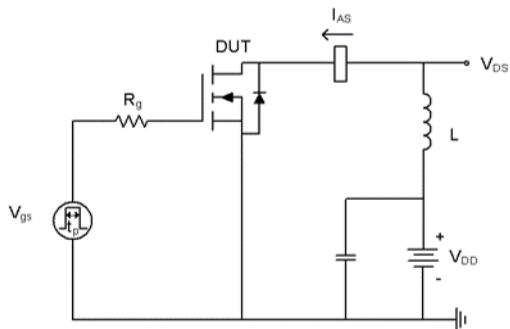


Fig18-1. Unclamped inductive load test circuit

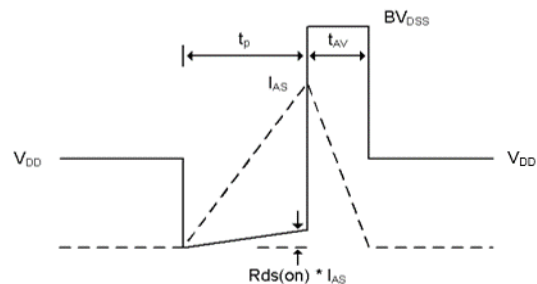
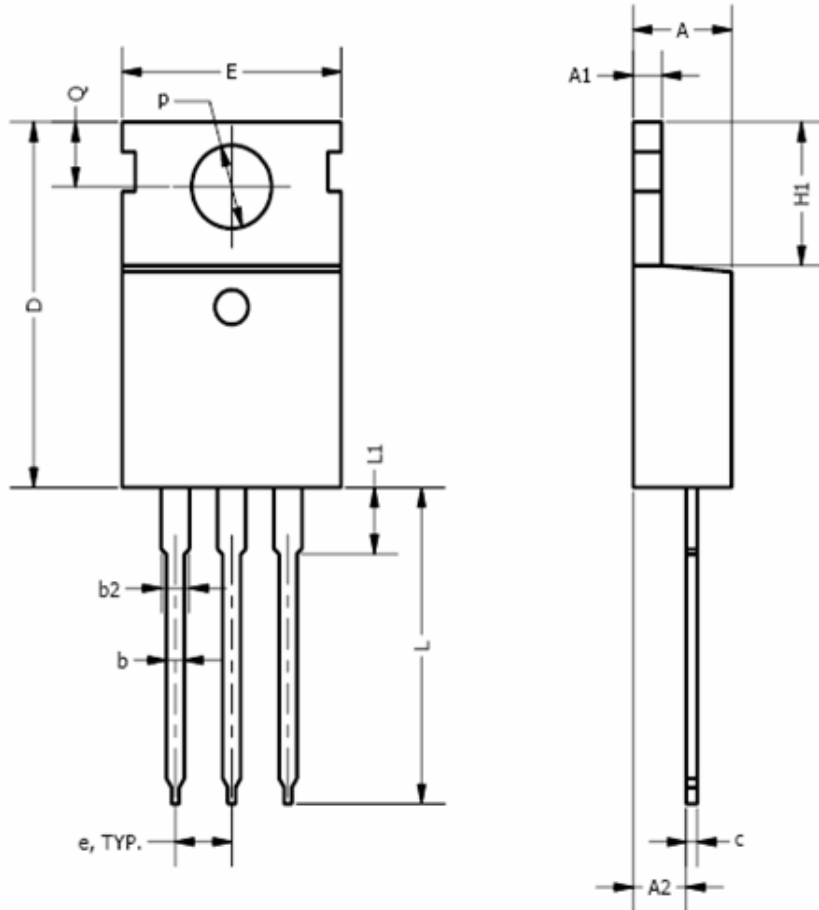


Fig18-2. Unclamped inductive waveform



**■ Physical Dimension**
**3 Leads, TO-220**



**Note : PKG Body Sizes exclude Mold Flash & Gate Burrs**

[unit : mm]

Symbol	Min	Nom	Max
A	3.56		4.83
A1	0.50		1.40
A2	2.03		2.92
b	0.38	0.69	1.02
b2	1.14	1.45	1.78
c	0.36		0.61
D	14.22		16.51
e	2.54 TYP		
E	9.65		10.67
H1	5.84		6.86
L	12.70		14.73
L1			6.35
ΦP	3.53		4.09
Q	2.54		3.43

**DISCLAIMER:**

The Products are not designed for use in hostile environments, including, without limitation, aircraft, nuclear power generation, medical appliances, and devices or systems in which malfunction of any Product can reasonably be expected to result in a personal injury. Seller's customers using or selling Seller's products for use in such applications do so at their own risk and agree to fully defend and indemnify Seller.

Magnachip reserves the right to change the specifications and circuitry without notice at any time. Magnachip does not consider responsibility for use of any circuitry other than circuitry entirely included in a Magnachip product.  Magnachip is a registered trademark of Magnachip Semiconductor Ltd.